

Worldwide Pollution Control Association

WPCA-Duke Energy
FF/HAPS Seminar
October 12-13, 2011

All presentations posted on this website are copyrighted by the Worldwide Pollution Control Association (WPCA). Any unauthorized downloading, attempts to modify or to incorporate into other presentations, link to other websites, or to obtain copies for any other purposes than the training of attendees to WPCA Conferences is expressly prohibited, unless approved in writing by the WPCA or the original presenter. The WPCA does not assume any liability for the accuracy or contents of any materials contained in this library which were presented and/or created by persons who were not employees of the WPCA.



Visit our website at www.wpca.info

W
P
C
A

Overview of Mercury Emissions Control and ACI

WPCA-Duke Energy Fabric Filter / HAPS Seminar

Presented by:

M. Brandon Looney, Southern Company Services

Su Liu, Southern Research Institute



Agenda

- Introduction
- Review of Policy/Regulatory Requirements
- Activated Carbon Injection
- Activated Carbons
- SO₃ and Activated Carbon
- Overview of Select Previous Test Programs
- Overview of Bowen Baghouse and Objectives
- Conclusion

Introduction – Hg and Forms

Hg (0)

Hg (+2)

Hg (P)

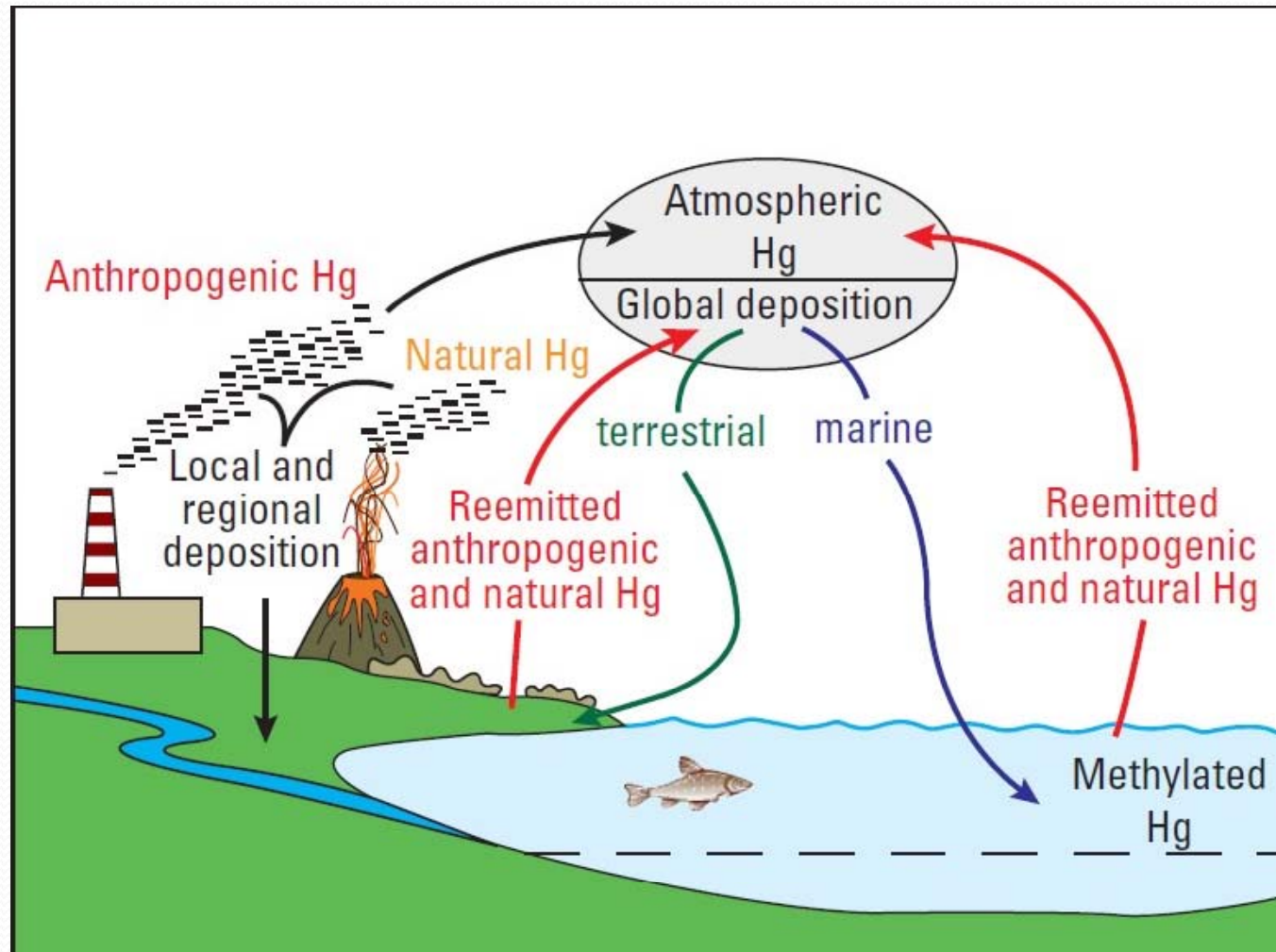

MACT Rule

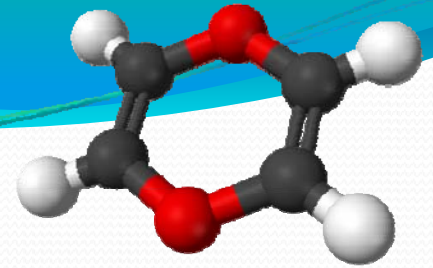

- 1990 and 2000 EPA did studies to determine it was “appropriate and necessary” to regulate Hg.
- They attempted it in CAMR, but was later thrown out.
- On March 16, 2011 the MACT was proposed with the final rule planned for November 16, 2011

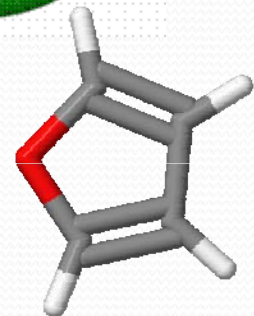
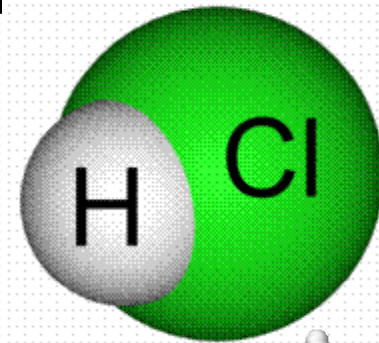

MACT Rule - Hg

- Based on performance of top 12% of plants
- EPA claims health benefits (Up to \$160B/yr) outweigh costs (\$11 B/yr)
- Limit set at $1.2\mu\text{g}/\text{m}^3$
- Implementation timeline set for 3 years
- Potential to apply for a fourth year

Fabric Filter Test Programs

- Phase I
 - Gaston Unit 3 COHPAC PJFF (TOXECON I) – LS EB
- Phase II-1
 - Sunflower Electric's Holcomb Unit 1 – SDA/FF - PRB
 - Great River Energy's Stanton Unit 10 – SDA/FF – ND Lignite
 - Basin Electric's Antelope Valley Unit 1 – SDA/FF – ND Lignite
- Phase II-2
 - Luminant Power's Big Brown Unit 2 – CS-ESP + COHPAC PJFF (TOXECON I) – TX Lignite/PRB Blend
- Phase III
 - KCPL's Hawthorne Unit 5 – SCR + SDA/FF – PRB
 - Rocky Mountain Power's Hardin Station – SDA/FF - PRB

Significant Issues Investigated

- Standard versus Chemically Treated Activated Carbons
 - Top Performers: Brominated Activated Carbons
 - Norit Americas DARCO Hg-LH, Sorbent Tech.'s B-PAC™ & Calgon Carbon's FLUEPAC™-MC Plus, ALSTOM Power's Mer-Clean™
 - Significantly reduces injection rate, offsets higher cost (\$0.50 vs \$0.85 per pound)
- SO₃ Impacts
 - Even low concentrations of SO₃ can interfere with ACI
 - Sources: SO₂ oxidation in the furnace, SO₂ oxidation across SCR, SO₃ FGC systems
 - SO₃ competes with Hg for adsorption sites on the carbon.
- Balance of Plant Issues

Activated Carbon Injection

Figure 1. Breakdown of ACI Installations by Coal Type

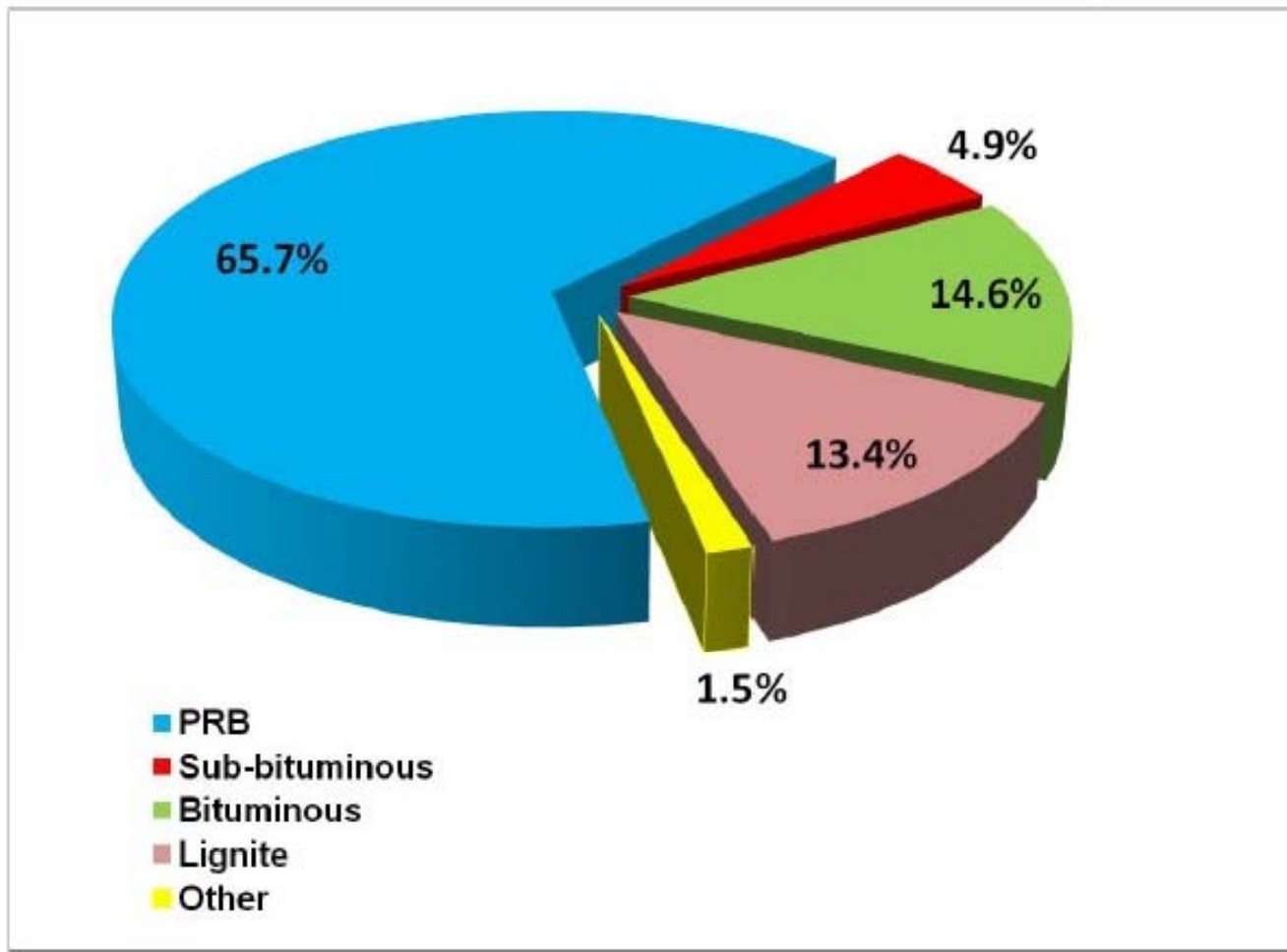

Source: *EPRI ACI SURVEY REPORT*, Randy Merritt

Activated Carbon Injection

Figure 2. Breakdown of ACI Installation by Particulate Control Device and Coal Type

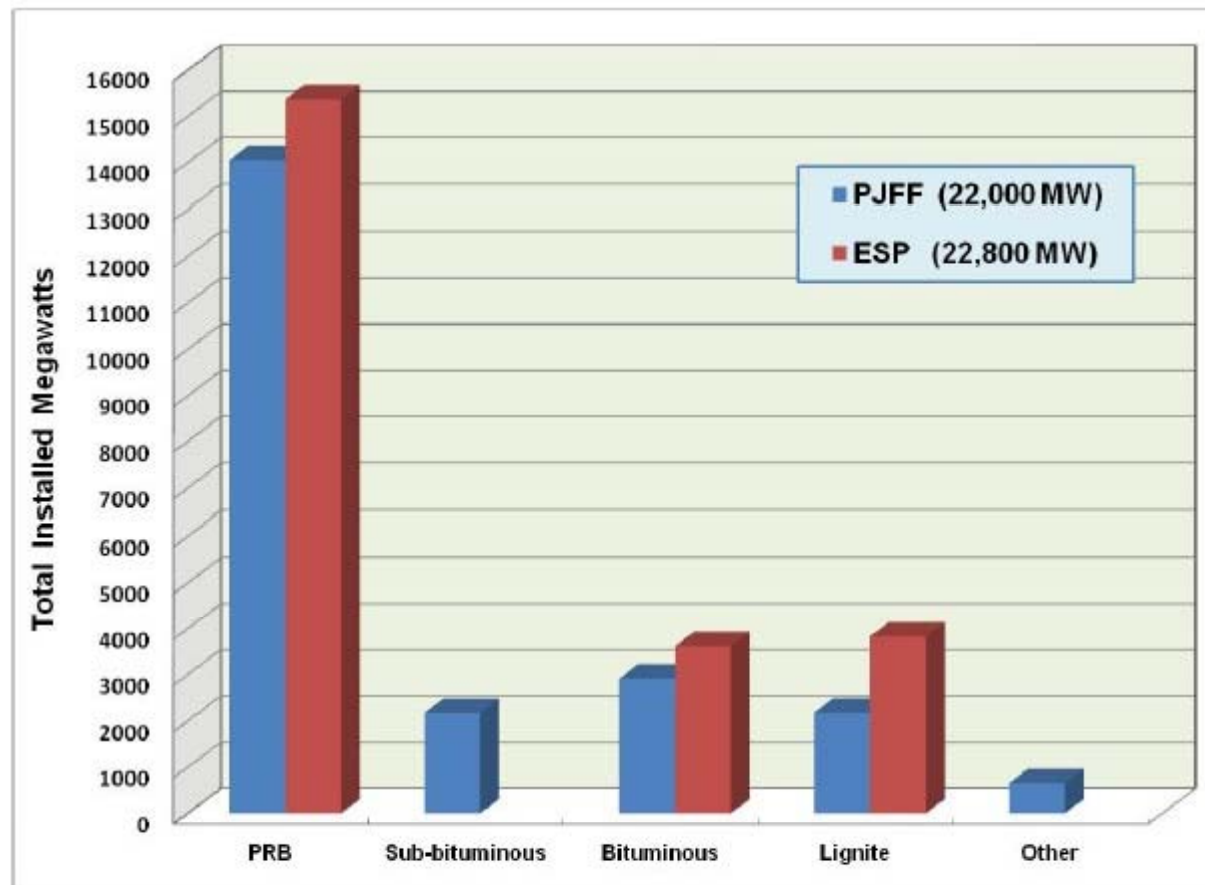

Source: *EPRI ACI SURVEY REPORT*, Randy Merritt

Activated Carbon Injection

Figure 4. Typical Arrangement of ACI System

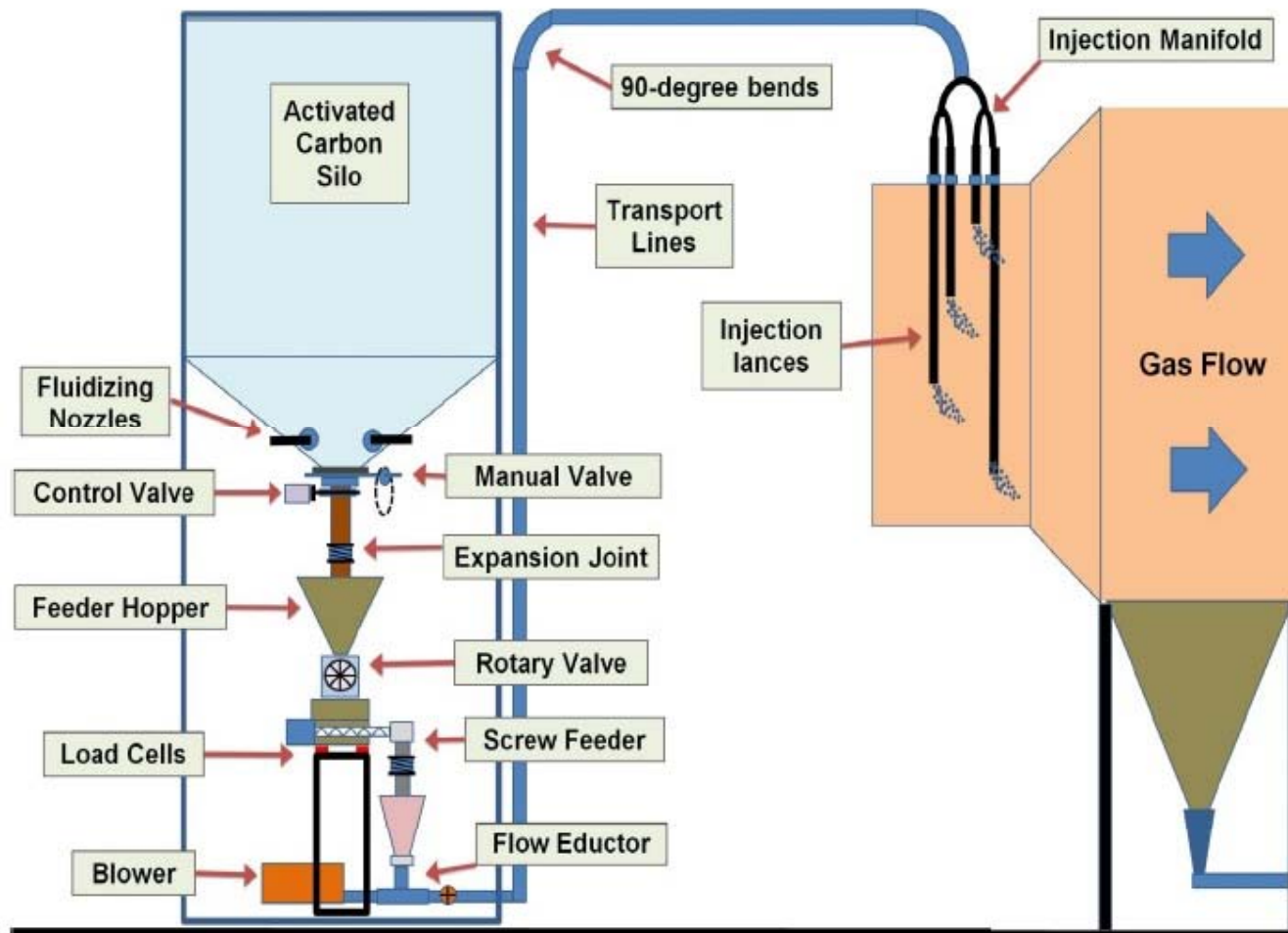

Source: *EPRI ACI SURVEY REPORT*, Randy Merritt

Injection Configuration

- Upstream of Baghouse
- Upstream of an ESP

Untreated Carbon Performance

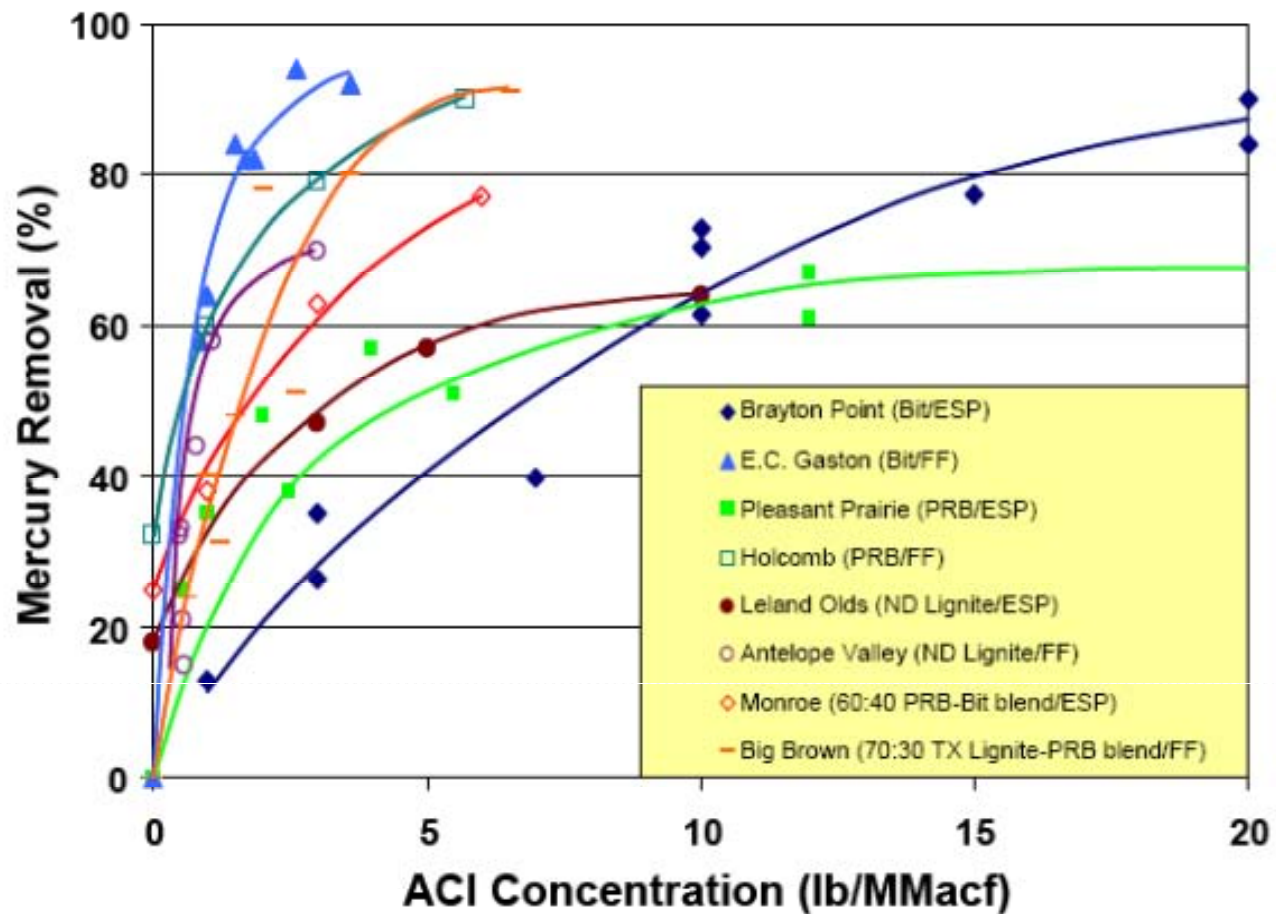

* All data generated using NORIT Americas' DARCO® Hg

Chemically-Treated Activated Carbons

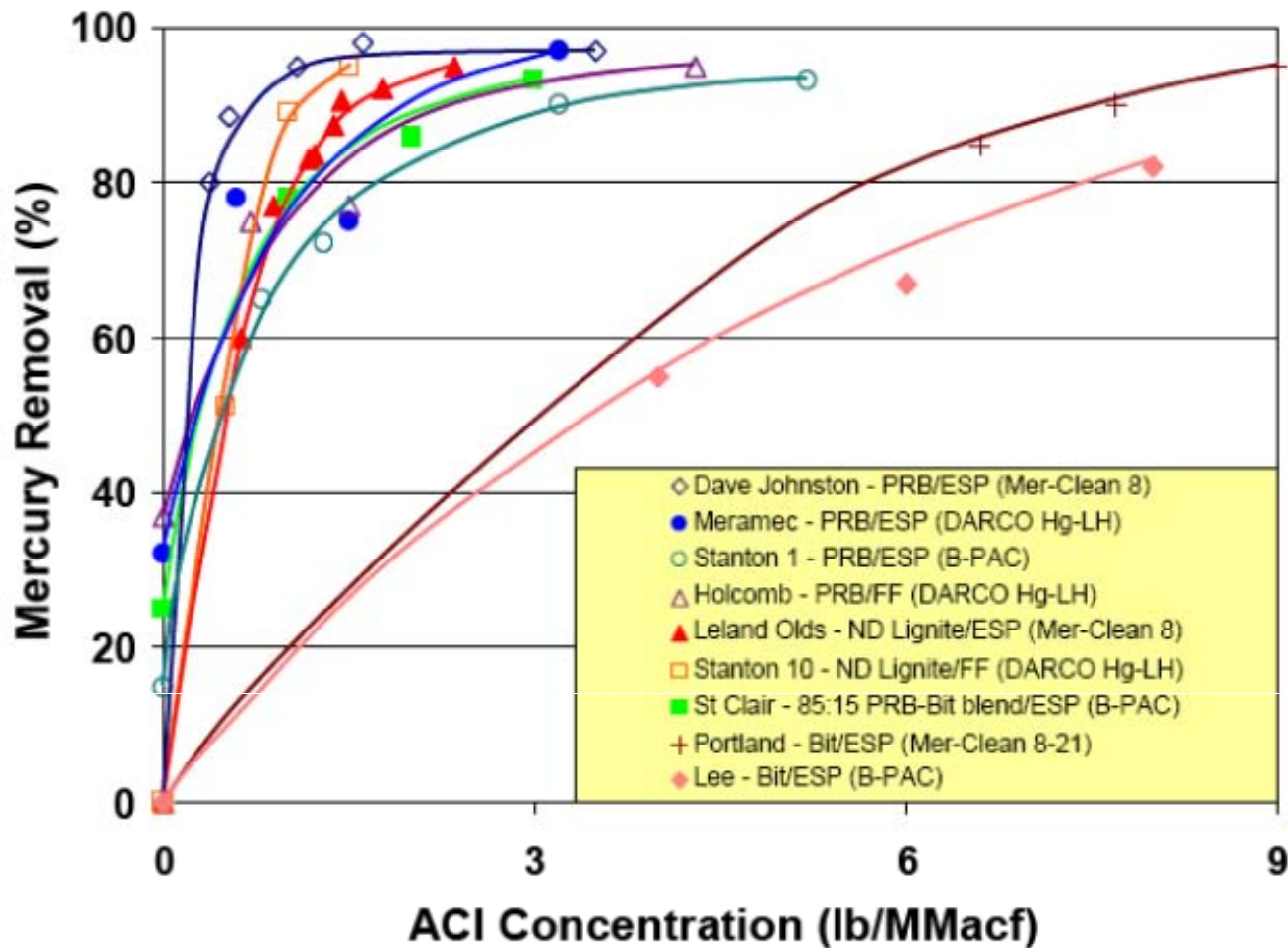

TOXECON™ Performance Curves

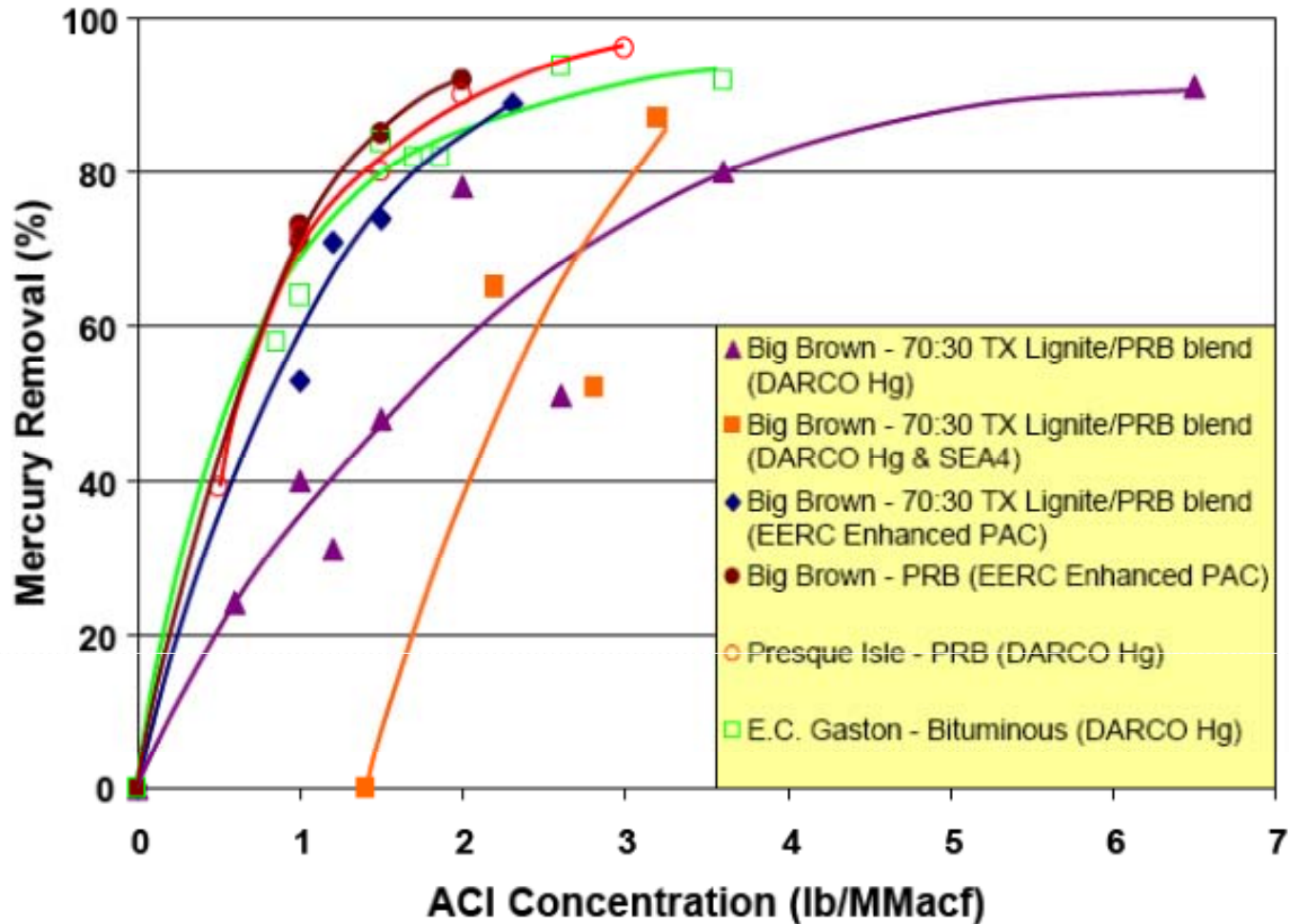

SO₃ and ACI Performance

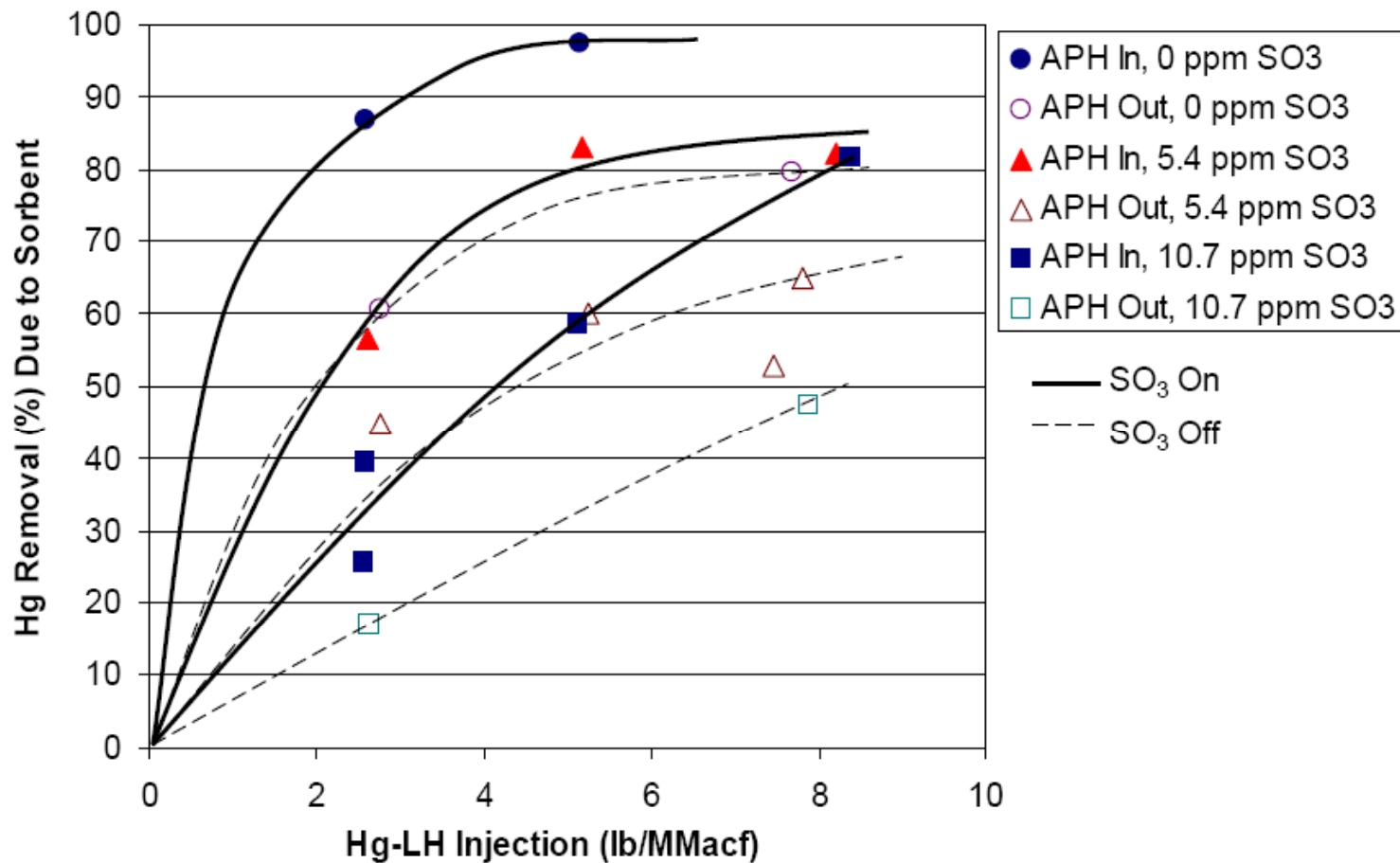



Effect of SO₃ on Mercury Removal

- SO₃ Negatively Impacts Carbon Performance
 - Similar observations from recent full-scale testing
 - SO₃ displaces mercury from active adsorption sites
- MRC Testing Approach
 - Testing performed with/without SO₃ injection
 - Facility inlet SO₃ ranged from 3 to 80 ppm
 - SO₃ removed upstream of the air heater using SBS process
 - Test matrix included carbon injection from 0 to 10 lb/MMacf
 - Multiple monitoring locations are available
 - Mercury measured at ESP inlet & outlet
 - Results were correlated with air heater inlet SO₃

Incremental Mercury Removal versus Air Heater Inlet SO₃

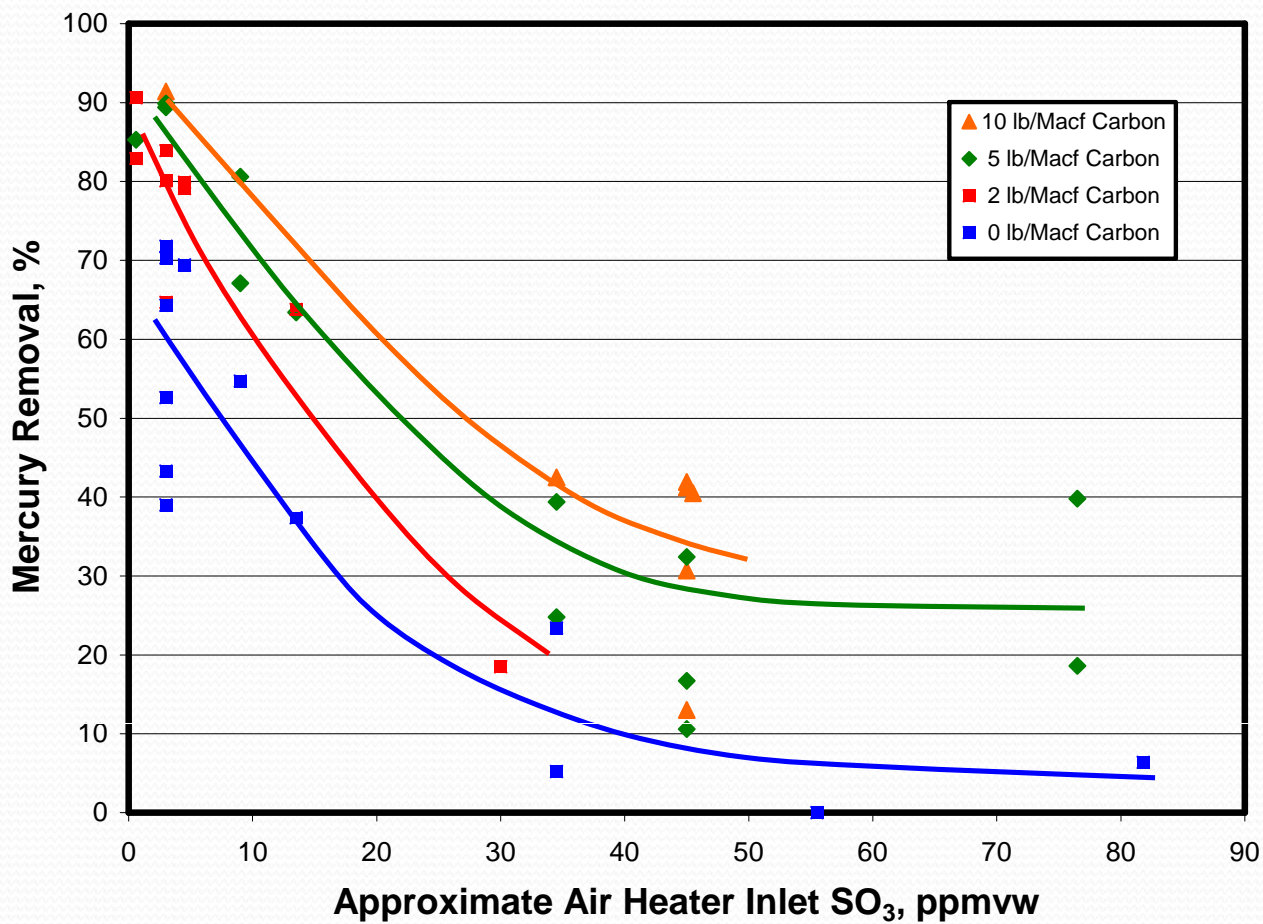

Incremental Mercury Removal versus ESP Outlet SO₃

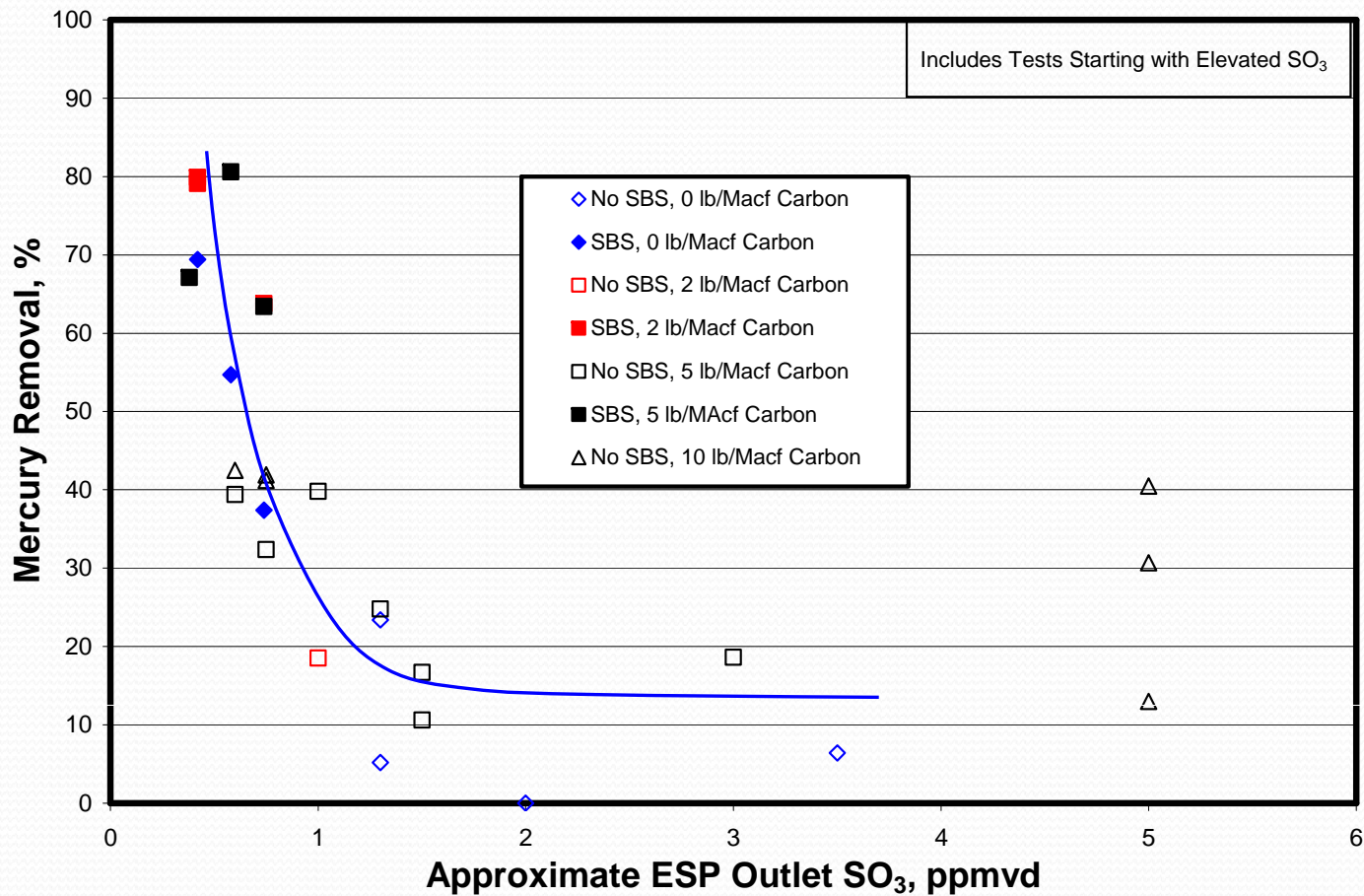

Effect of SO₃ Removal on ESP Total Hg Removal Efficiency

AH Inlet SO₃ Concentration of 40 ppm

@

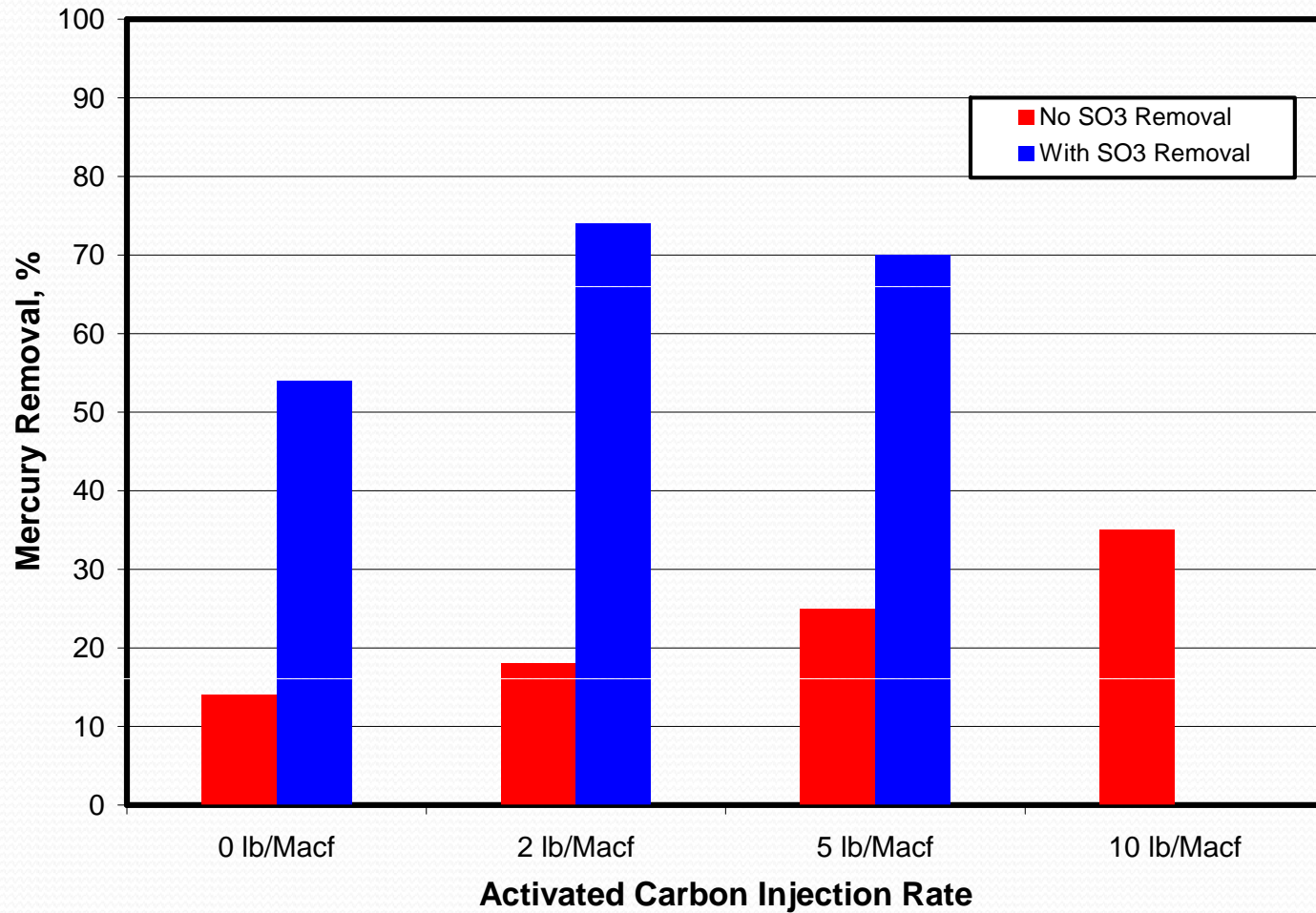



Previous Programs

- Presque Isle (WE Energies)
- Scherer (Southern Company)

Presque Isle (WE Energies Clean Coal Demonstration)

Presque Isle Power Plant

TOXECON™

Sorbent Injection

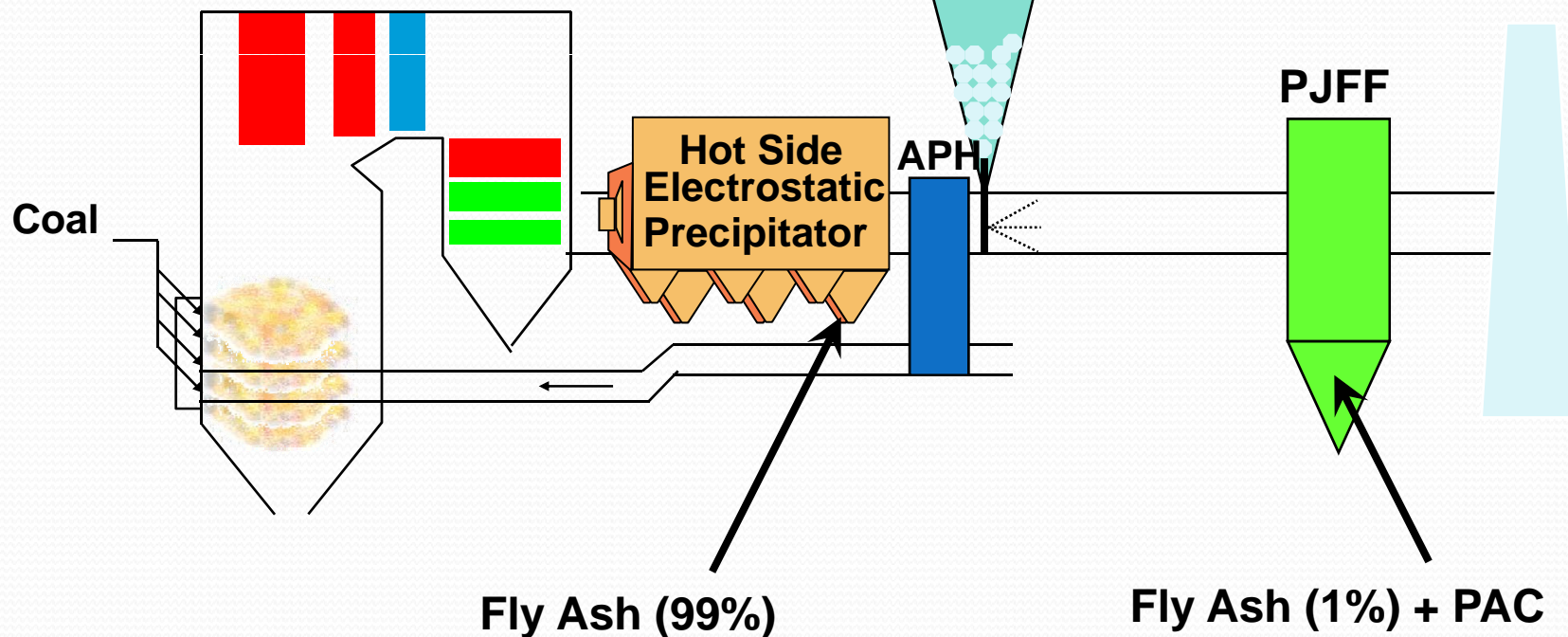

Presque Isle

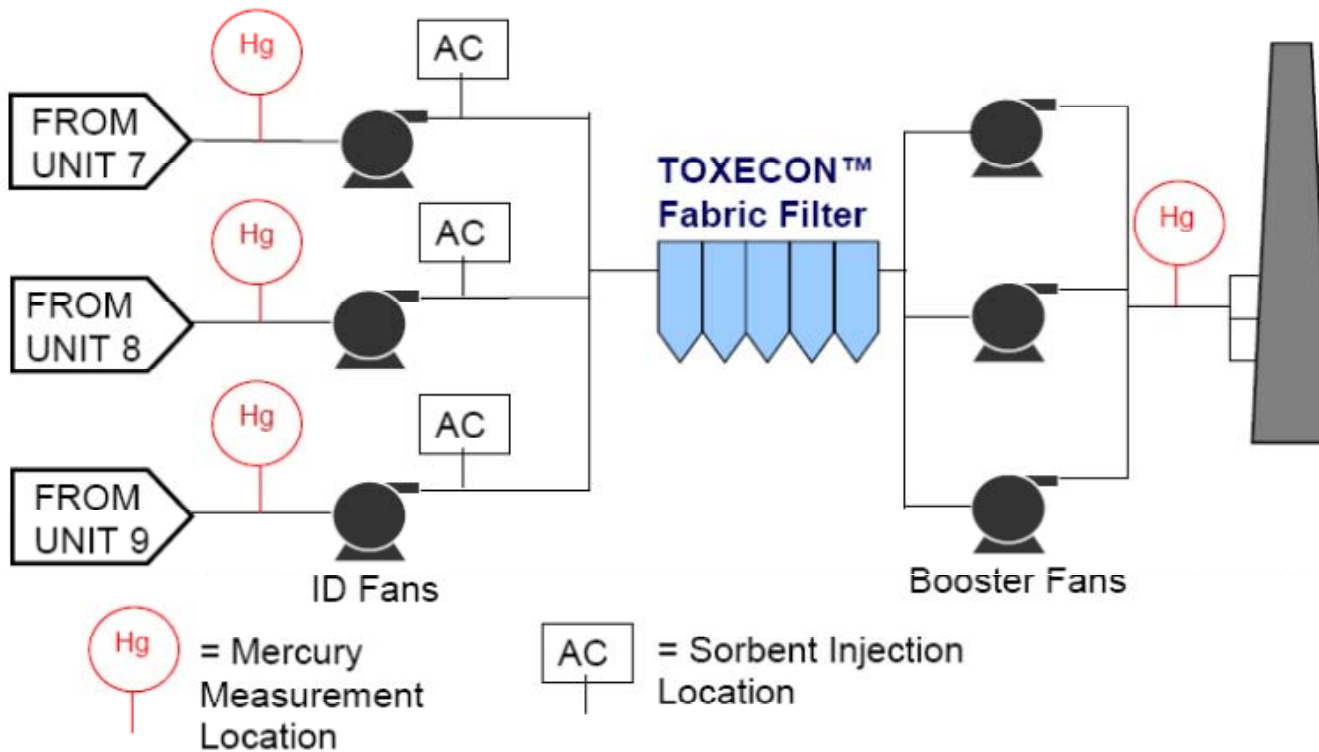

Presque Isle



Baghouse Design

- Pulse-Jet Fabric Filter
 - Supplied by Wheelabrator
 - On-line cleaning
 - Ability for off-line cleaning
- Air-To-Cloth Ratio
 - 5.5 ft/min (gross)
 - 1,080,000 acfm
- 10 Compartments
 - 648 bags/compartment
 - PPS fabric

Operating Parameters

- Norit Americas DARCO Hg, 1.7 lb/MMacf
- Baghouse dP Set Points
 - 3 units in service, 6.5 inches wc
 - 2 units in service, 4.6 inches wc
 - 1 unit in service, 2.3 inches wc
- Default Cleaning Timer
 - 3 units in service, 1 hour
 - 2 units in service, 2 hours
 - 1 unit in service, 4 hours
- Ash is pulled every four hours
- Ash hopper heaters < 300F wall temperature

Results

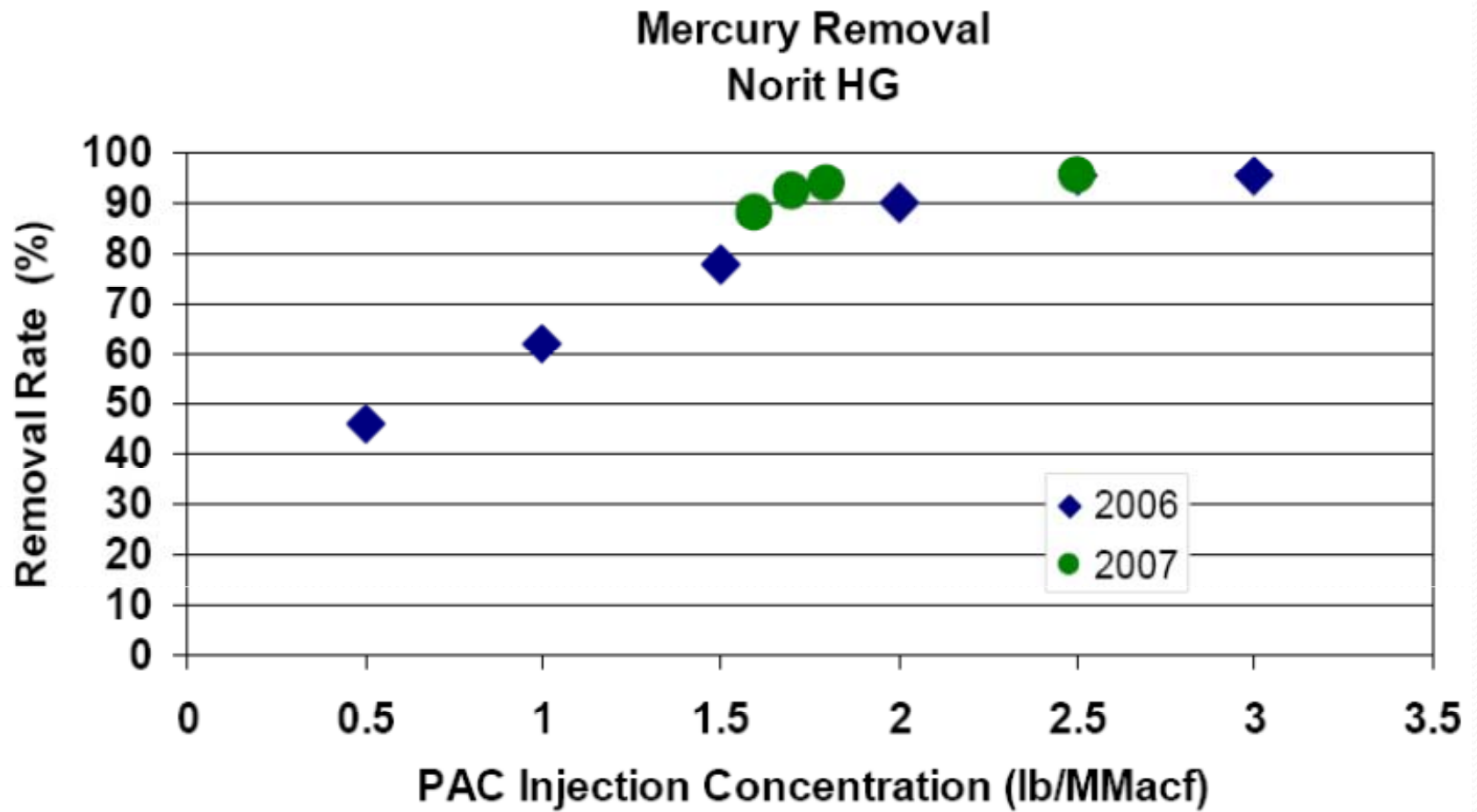

November 2007 Performance Data

Daily Averages November 2007

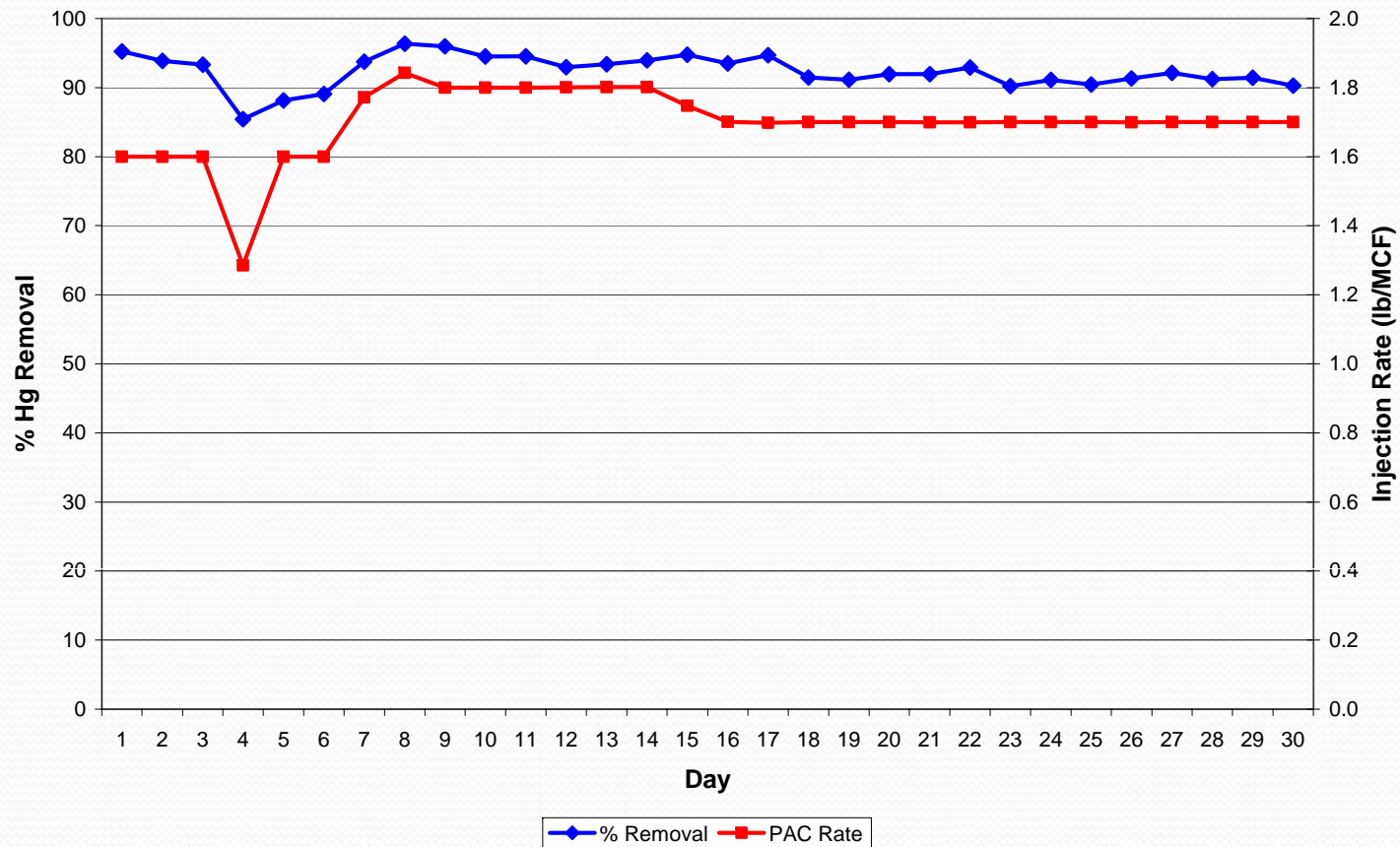

Daily Averages December 2007

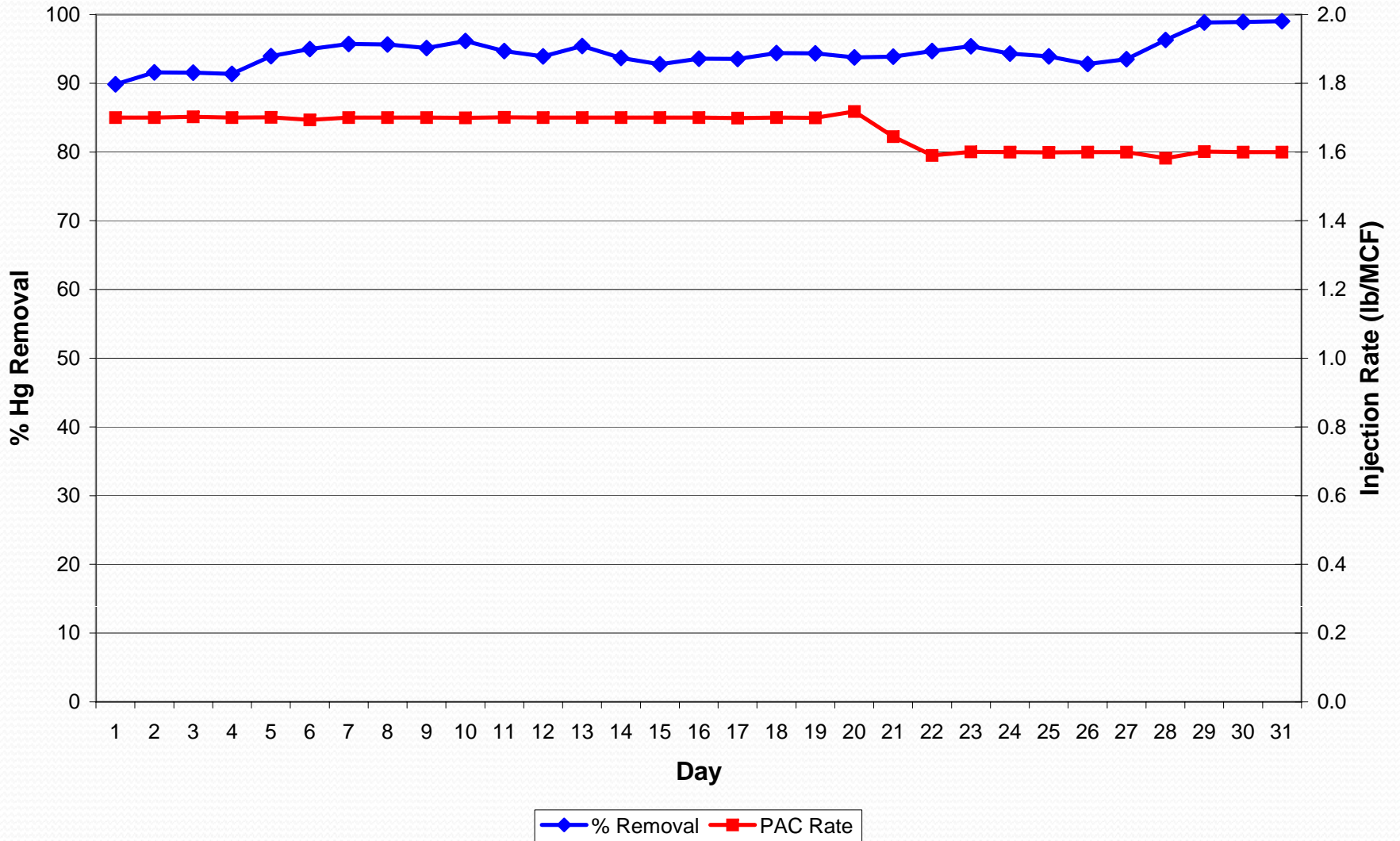

Daily Averages January 2008

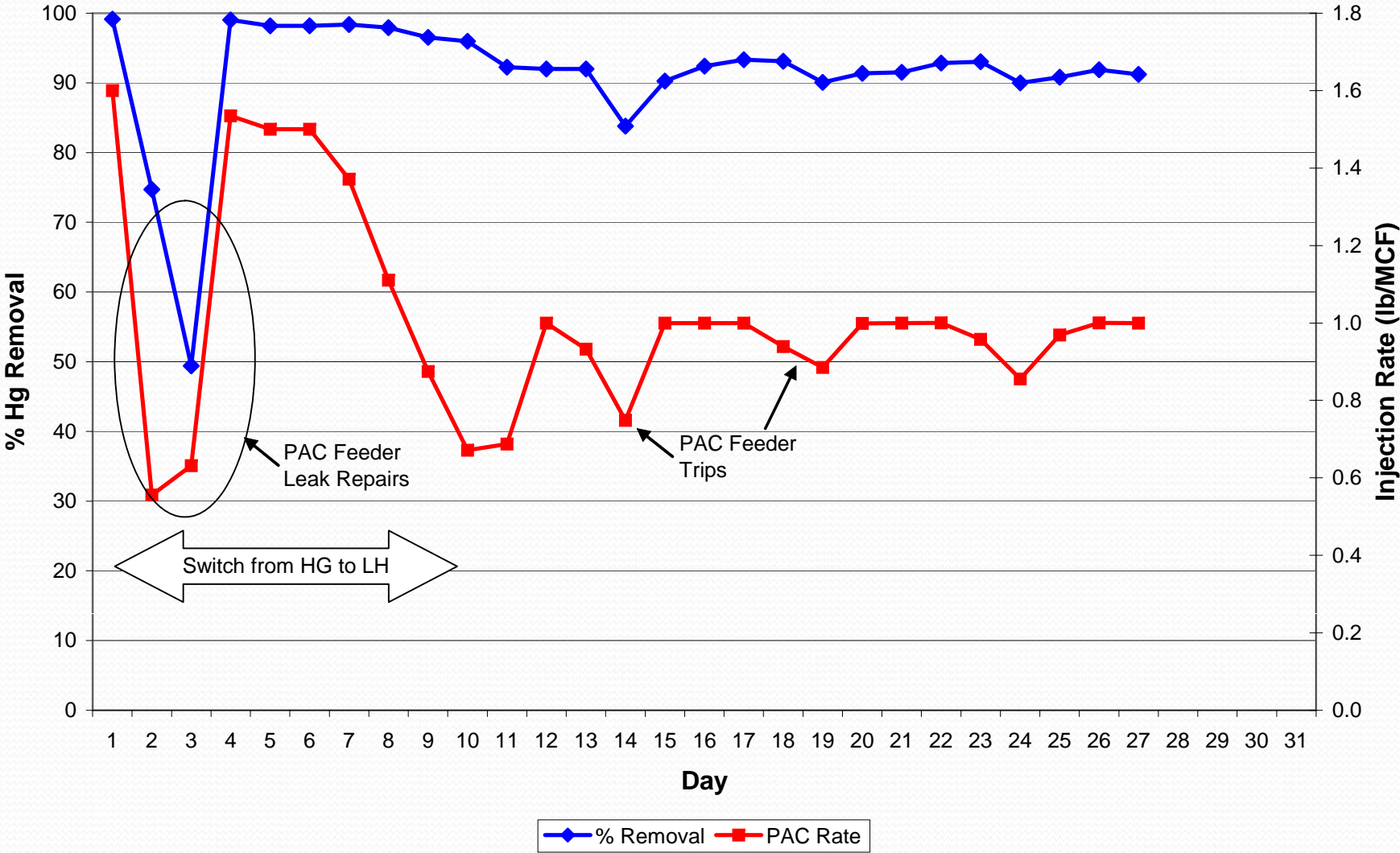

Presque Isle Review

- Carbon injection effectively removes mercury
- Standard activated carbon is sensitive to temperature at low injection levels. A 3% reduction between 300 and 330 F at rates of 1.6 to 2.5 lb/MMacf.
- Bag cleaning based on time reduces temperature sensitivity.
- 90% mercury removal was maintained by Norit DARCO Hg and Hg-LH at injection rates of 3 and 2 lb/MMacf, respectively.
- PAC/ash mixtures can ignite with sufficient time and quantity at temperatures above 400 F.
- PAC/ash mixture is “sticky” and can lead to hopper bridging and buildup preventing effective hopper evacuation.



Presque Isle Review

- Minimize PAC/ash storage in hoppers by emptying hoppers frequently and avoid buildup issues.
- Control hopper temperatures to 300F or below, if practical. Minimize hopper heater use if possible.
- Install additional thermocouples or a CO monitor to help detect spontaneous combustion if it occurs.
- Timed bag cleaning will provide steady deposition of ash to the hoppers and also helps to provide more consistent and steady mercury removal.
- O&M costs are expected to be \$0.81/KWH annually.
- This equates to about \$11,000 per pound of mercury removed. This is expected to be on the order of 80 to 100 pounds per year.

Georgia Power Company Plant Scherer

- **Four 880 MW PC Boilers**
- **100% PRB Coal**
- **Existing Cold-Side ESP**

Three Phase Retrofit Project

- 1. TOXECON for Hg Control**
- 2. Wet FGD for SO₂ Control**
- 3. SCR for NO_x Control**



Baghouse Design Parameters

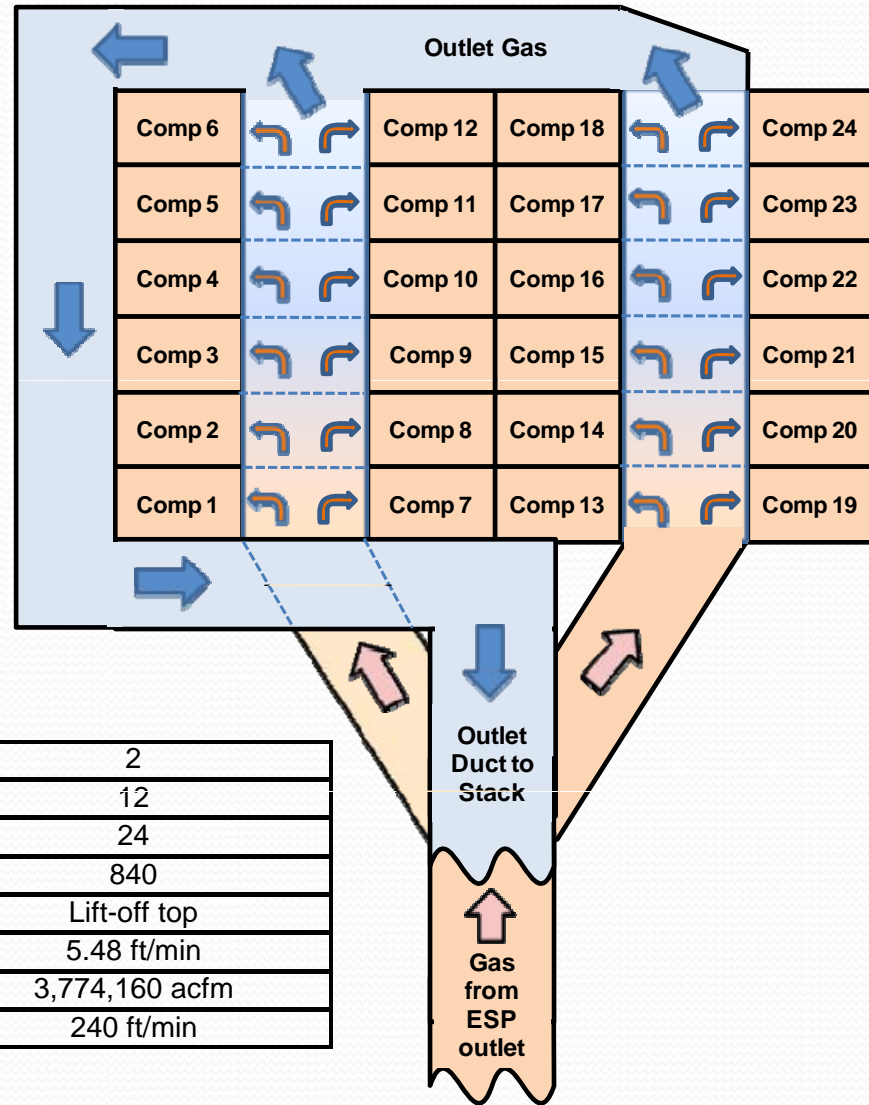

Number of casings	2
Compartments per casing	12
Total compartments	24
Bags per compartment	840
Filter bag access	Lift-off top
Air-to-Cloth ratio (gross)	5.48 ft/min
Design gas volume	3,774,160 acfm
Compartment can velocity	240 ft/min

Baghouse Design Parameters

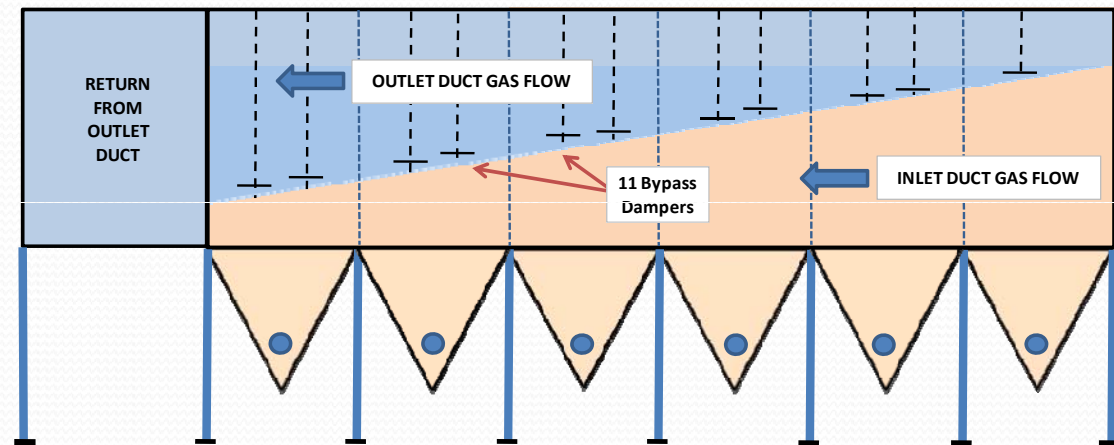
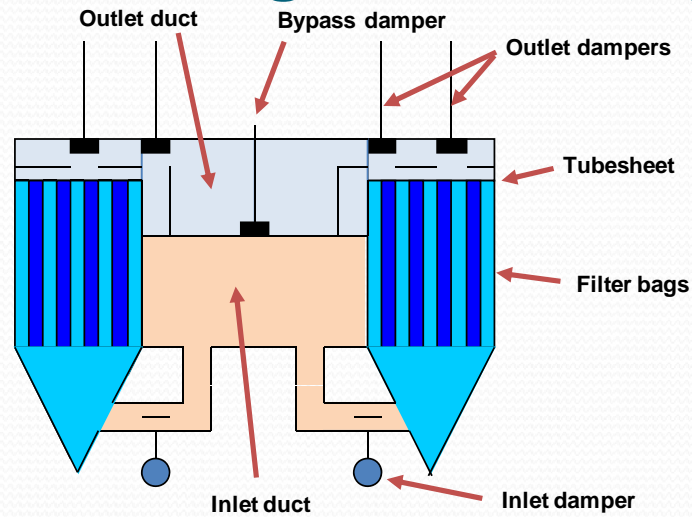

TOXECON Operation

Scherer Unit 2

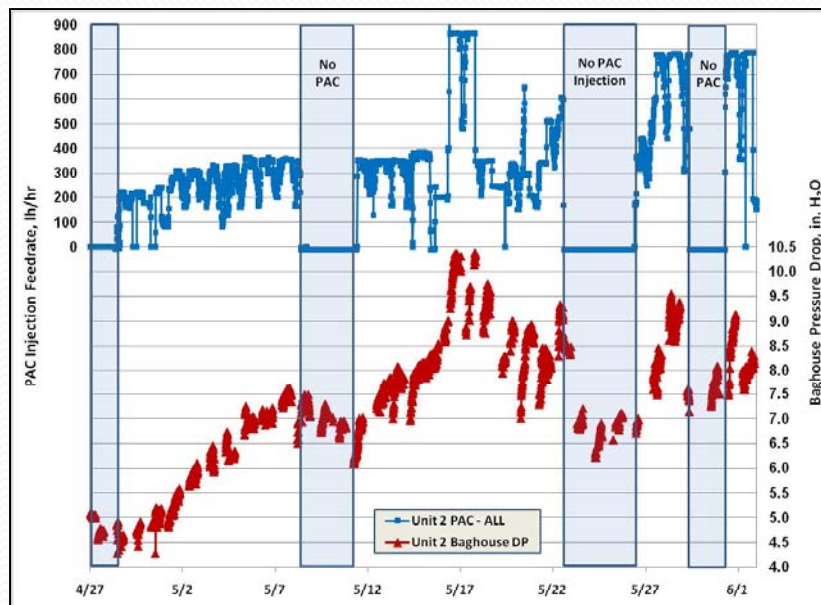

Scherer Unit 3

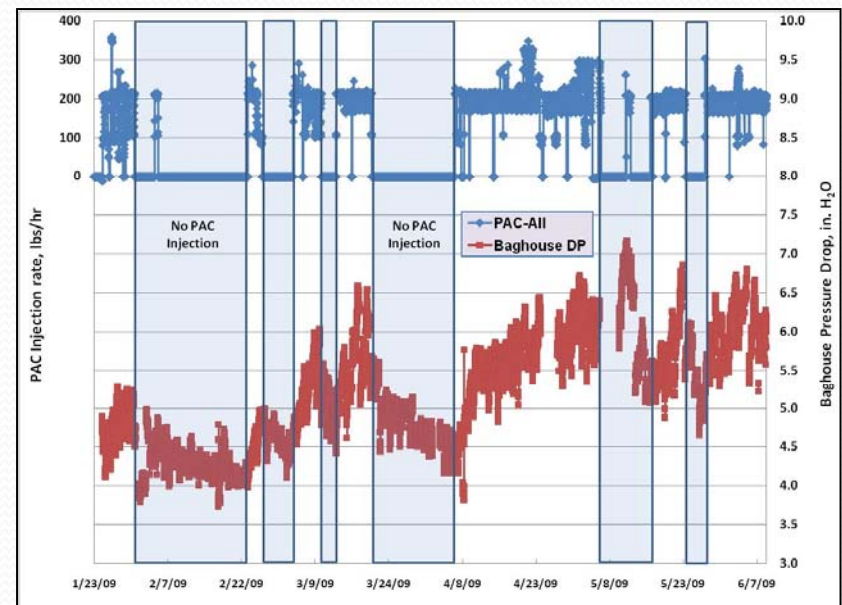

High Pressure Drop on Unit 2

Unexpected Sensitivity to Carbon Injection on Units 2 and 3

TOXECON Operational Changes

Scherer Unit 3

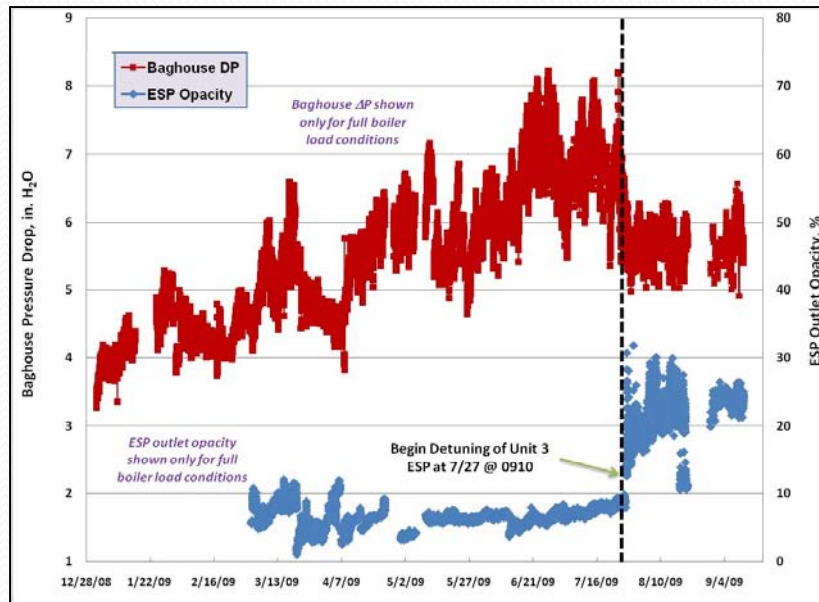

Scherer Unit 2

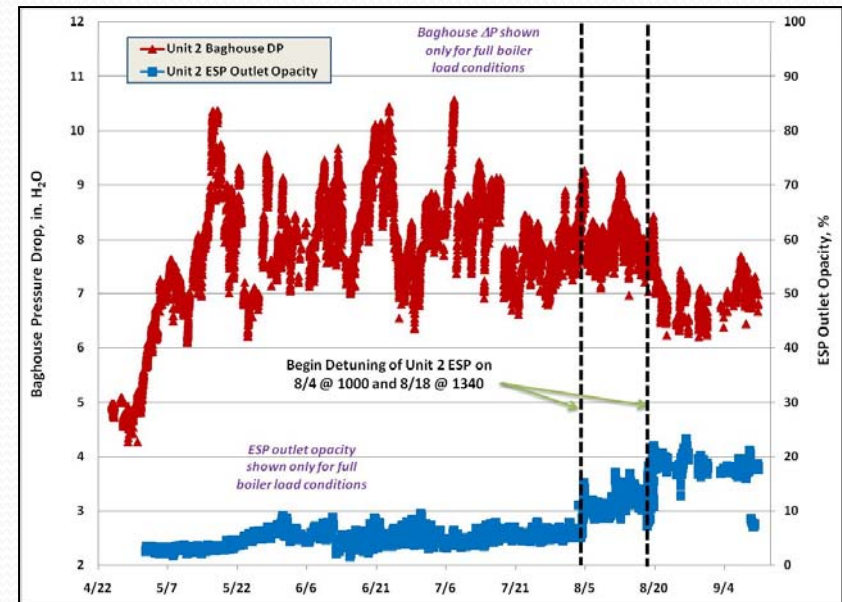

1. Reduce ACI to minimum injection rate
2. Conduct off-line cleaning for several days to restore reasonable pressure drop
3. Detune the ESP to increase fly ash loading
4. Determine baghouse pressure drop sensitivity to increased ash loading
5. Increase ACI to normal injection rate

Baghouse Cleaning Effectiveness

		Cumulative Hours	Percent of Time
Scherer 1	Normal Cleaning	2820	89.0%
	Continuous Cleaning	318	10.0%
	Off-Line Cleaning	30	0.9%
Scherer 2	Normal Cleaning	1593	18.3%
	Continuous Cleaning	3828	43.9%
	Off-Line Cleaning	3298	37.9%
Scherer 3	Normal Cleaning	7702	84.2%
	Continuous Cleaning	1199	13.1%
	Off-Line Cleaning	244	2.7%

Baghouse Cleans on Back-up Timer under normal operation

Baghouse Cleans Continuously when Pressure Drop exceeds Set Point

Baghouse Cleans Off-Line based on Operator Intervention

TOXECON Mercury Performance

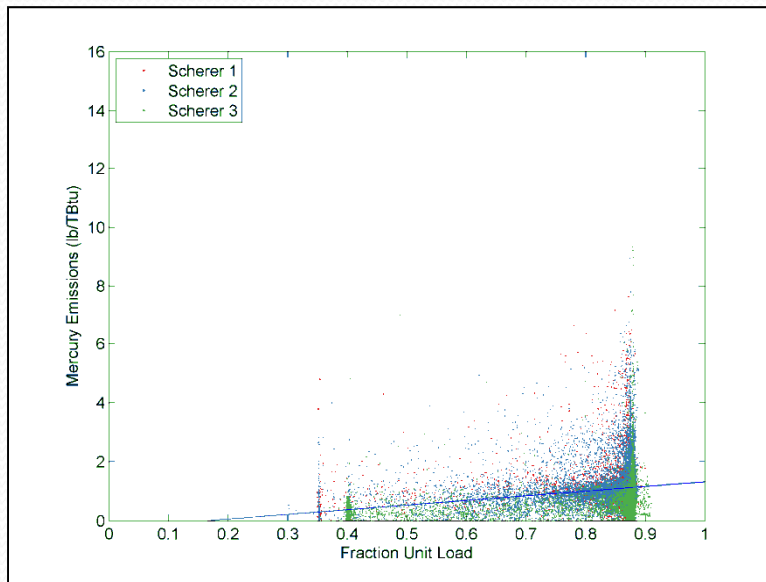

Increased Boiler Load and Flue Gas Temperature Correlate with Increased Mercury Emission

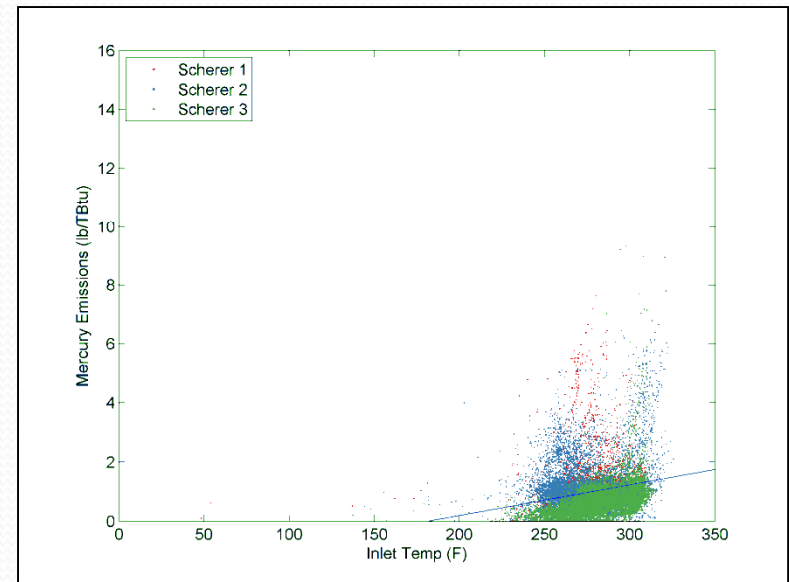

TOXECON Mercury Performance

Increased Pressure Drop Correlates
with Increased Mercury Emission

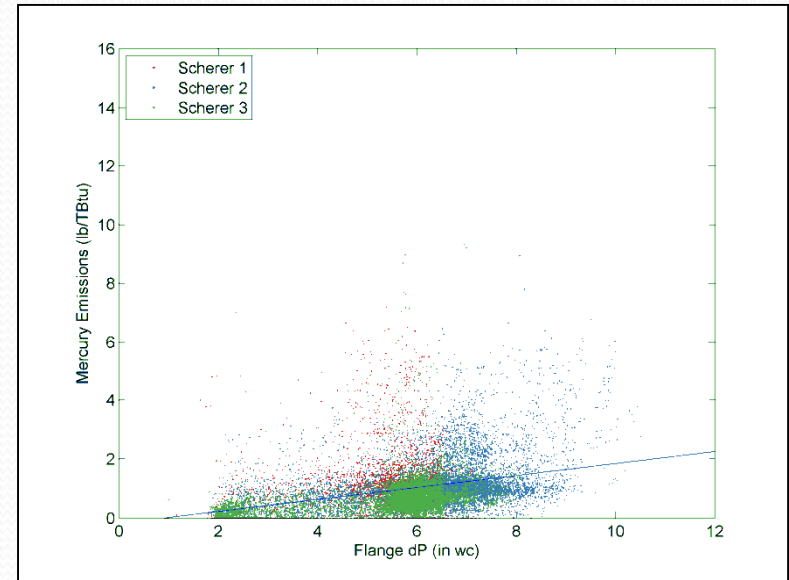
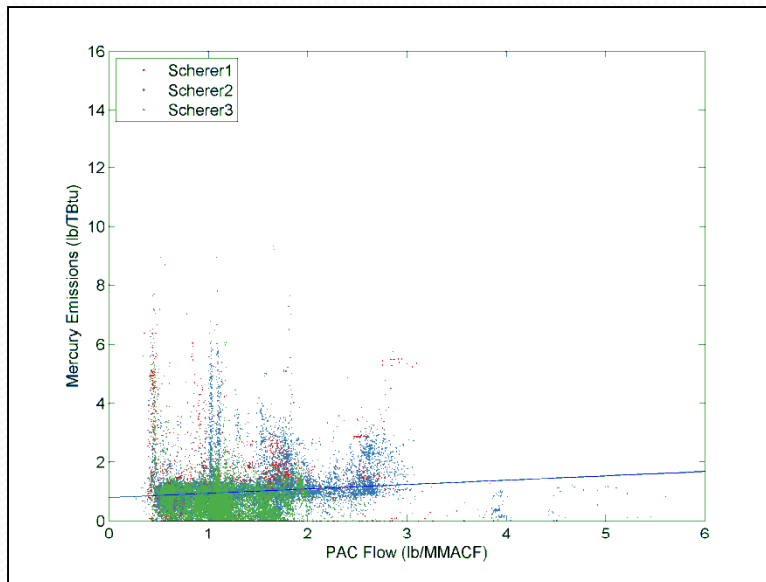

Increased Carbon Injection Rate
Does Not Correlate with Decreased
Mercury Emission

Bowen PJFF

Demonstration

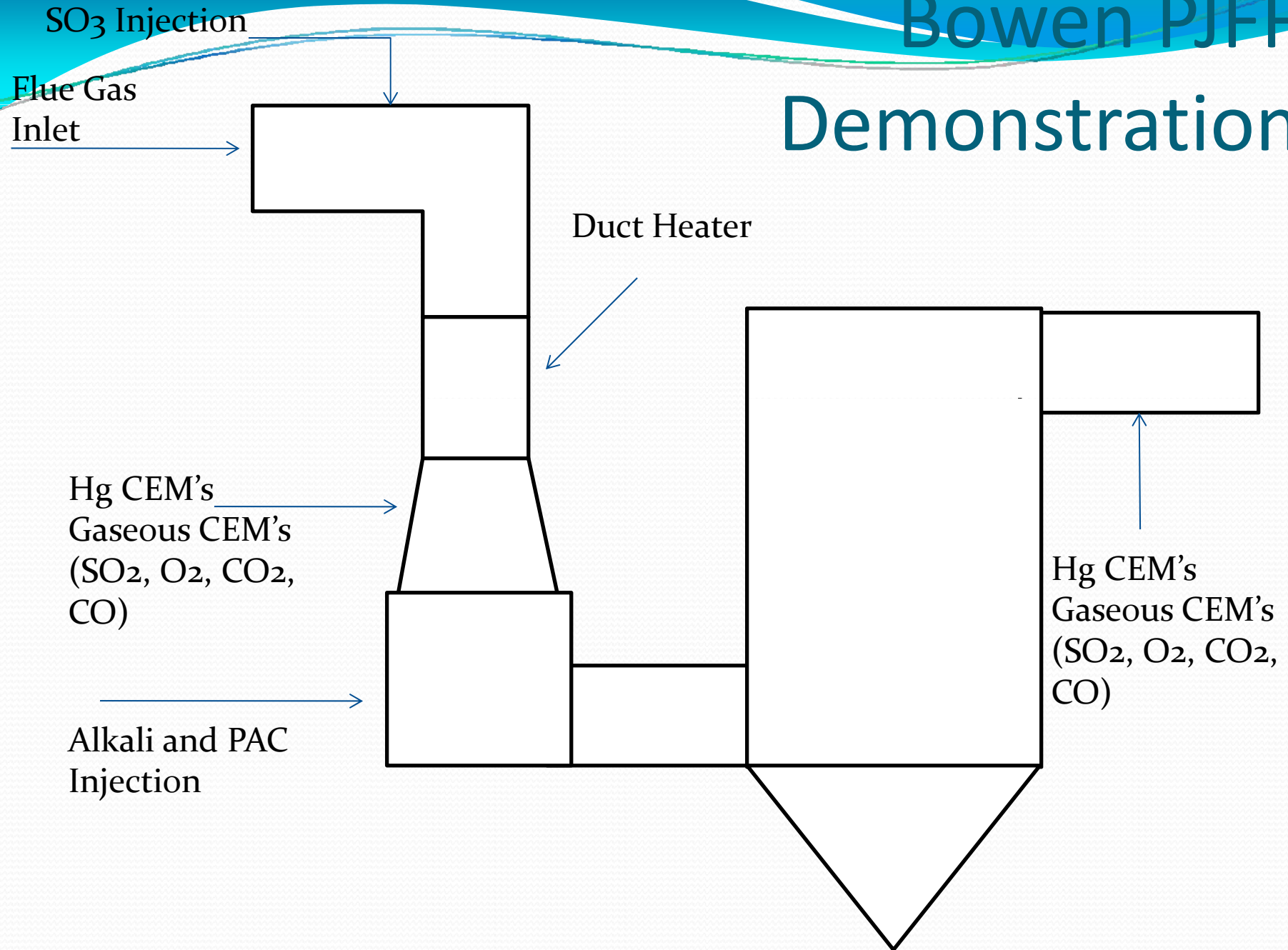

Bowen PJFF Demonstration

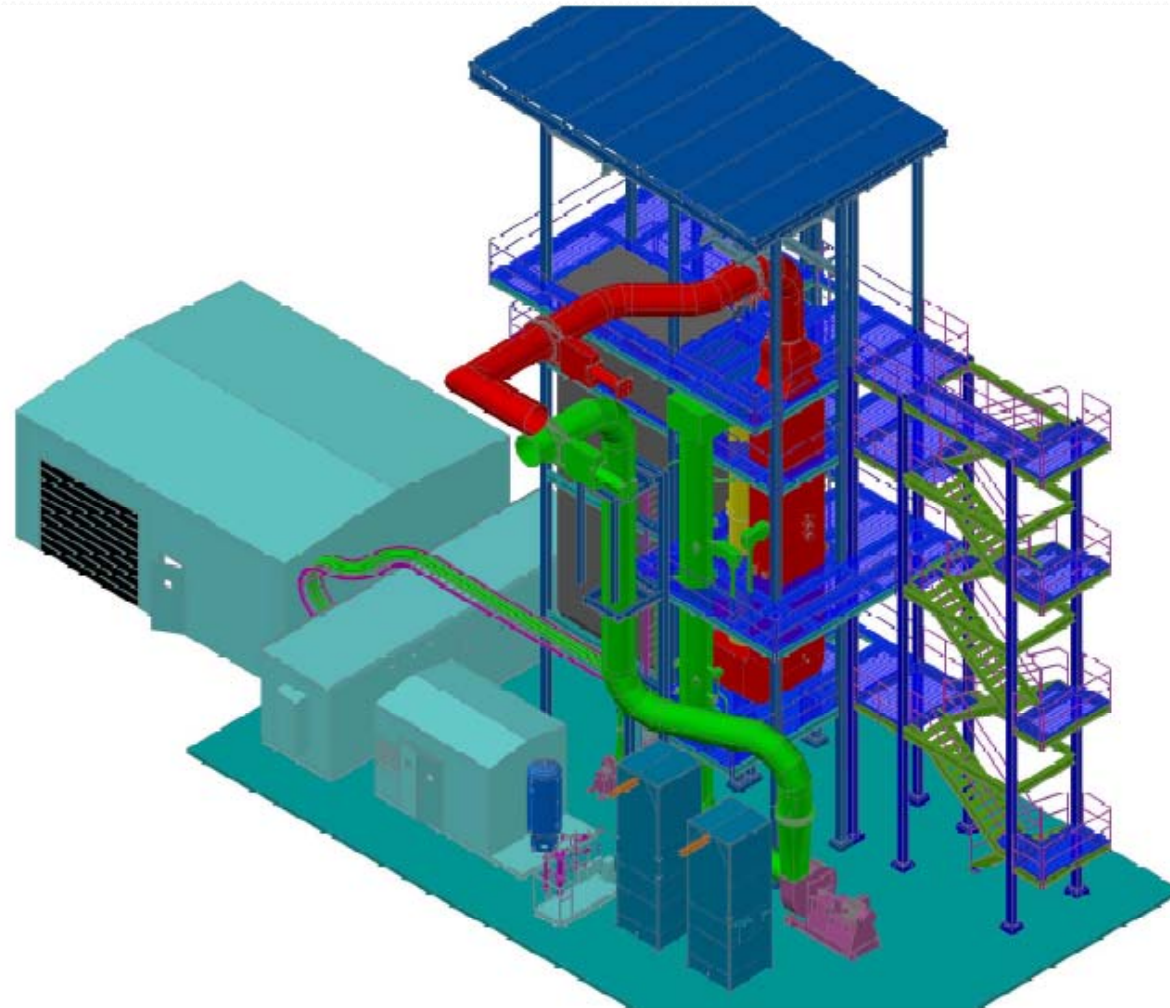

Bowen PJFF Pilot

- Pilot baghouse designed by ADA-ES and under fabrication by McAbee Construction.
- 5 MW scale on Bowen Unit 2, Eastern App. Coal (Bit)
- Sulfur content between 1.5-3% with potential to 4%
- Test program divided into two parts:
 - Parametric Phase (6 months~)
 - Long Term Phase (1-2 years)



Conclusions

- Fabric filters offer the most cost effective direct technology for 90% or better Hg removal with ACI.
- High removal efficiency with low injection rates minimizes CUB impacts.
- COHPAC type arrangements (TOXECON I & II) can eliminate ash sales issues.
- Chemically treated carbons can further minimize ACI rates, considering cost tradeoffs.
- Each site will have its own unique issues – coal type, SO₃ concentration, flue gas temperature- to be considered.

Questions

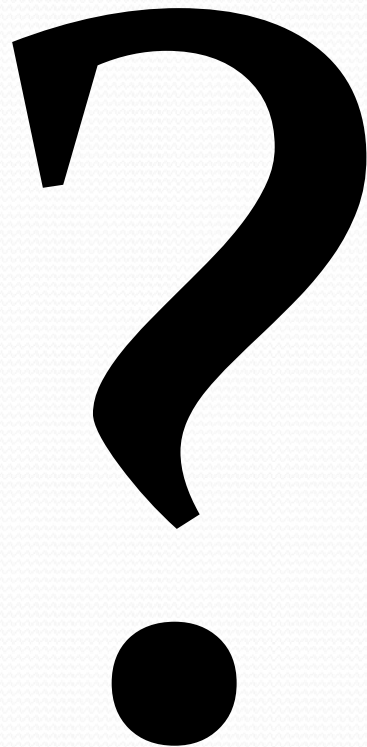



Sources

- Mercury in U.S. Coal—Abundance, Distribution, and Modes of Occurrence
- Georgia Power Company
Plant Scherer TOXECON Performance Optimization and Experience, M. Brandon Looney
- TOXECON™ Clean Coal Demonstration for Mercury and Multi-Pollutant Control, Steve Serenne
- Mercury Removal and ESP Capture of Activated Carbon – Impacts of Flue Gas Characteristics and ESP Operating Variables, Kenneth Cushing
- Control of Mercury Emissions at Coal-fired Boilers Using Fabric Filters, Kenneth Cushing



Sources

- Feeley, Thomas J. and Andrew P. Jones, “[An Update on DOE/NETL’s Mercury Control Technology Field Testing Program](#),” United States Department of Energy, January 2008.
- Derenne, S.; Sartorelli, P.; Bustard, J.; Stewart, R.; Sjostrom, S.; Johnson, P.; McMillan, M.; Sudhoff, F; Chang, R. “[TOXECON™ Clean Coal Demonstration for Mercury and Multipollutant Control at the Presque Isle Power Plant](#).” In Proceedings of the Air Quality VI Conference, Arlington, VA, September 24-27, 2007.
- Sjostrom, S; Dillon, M.; Donnelly, B.; Bustard, J.; Filipelli, G.; Glesmann, R.; Orscheln, T.; Wahlert, S.; Chang, R.; O’Palko, A. “[Influence of SO₃ on Mercury Removal with Activated Carbon: Full-Scale Results](#).” In Proceedings of the Air Quality VI Conference, Arlington, VA, September 24-27, 2007.
- Derenne, Steve. “[TOXECON Retrofit for Mercury and Multipollutant Control](#).” USDOE 2007 Mercury Control Technology Conference, Pittsburgh, PA, December 11-13, 2007.